



# PARTS BREAKDOWN

*World Leader in Lift Systems*

## Models:

- |        |         |
|--------|---------|
| AR43-1 | AR43-11 |
| SM41-1 | SM41R   |
| SM43-1 | SM43-11 |
| SM44-4 | SM44R-4 |

**ATTENTION!!!**  
 READ ALL MANUALS THOROUGHLY  
**BEFORE**  
 INSTALLING, OPERATING, OR MAINTAINING  
 THE LIFT

## Table of Contents

### Runways, Columns and Power Units:

AR43-1, AR43-11 .....	1 & 2
SM41-1, SM41R, SM43-1, SM43-11 .....	3 & 4
SM44-4, SM44R-4 .....	5 & 6
<b>SUB-ASSEMBLIES</b> .....	7-10

*World Leader in Lift Systems*



World Headquarters:  
**ROTARY LIFT**  
**A DOVER INDUSTRIES COMPANY**  
 2700 Lanier Drive  
 Madison, IN 47250-1753 USA  
 Phone toll-free: 1-800-445-5438  
 Phone: (812) 273-1622  
 Fax toll-free: 1-800-822-6502  
 Fax: (812) 273-6502  
 E-mail: [userlink@rotarylif.com](mailto:userlink@rotarylif.com)  
 Web site: [www.rotarylif.com](http://www.rotarylif.com)

For Canada:  
**DOVER CORP. (CANADA) LTD.**  
**ROTARY LIFT DIVISION**  
 130 Bridgeland Avenue Unit 210  
 Toronto, Ontario M6A 1Z4  
 Phone: (416) 256-4100  
 Fax: (416) 256-3924

For United Kingdom & Republic of Ireland:  
**ROTARY LIFT (UK) LIMITED**  
 Madison House  
 2 Park Road  
 Dartford, Kent  
 DA1 1SL  
 Phone: +44 (0) 1322 223323  
 Fax: +44 (0) 1322 222454

For Europe:  
**ROTARY LIFT EUROPE**  
 Berlinger Ring 163 B  
 D-64625 Bensheim  
 Phone: +49 (0) 6251 787037  
 Fax: +49 (0) 6251 787038

**MODELS:**  
**AR43-1, AR43-11**

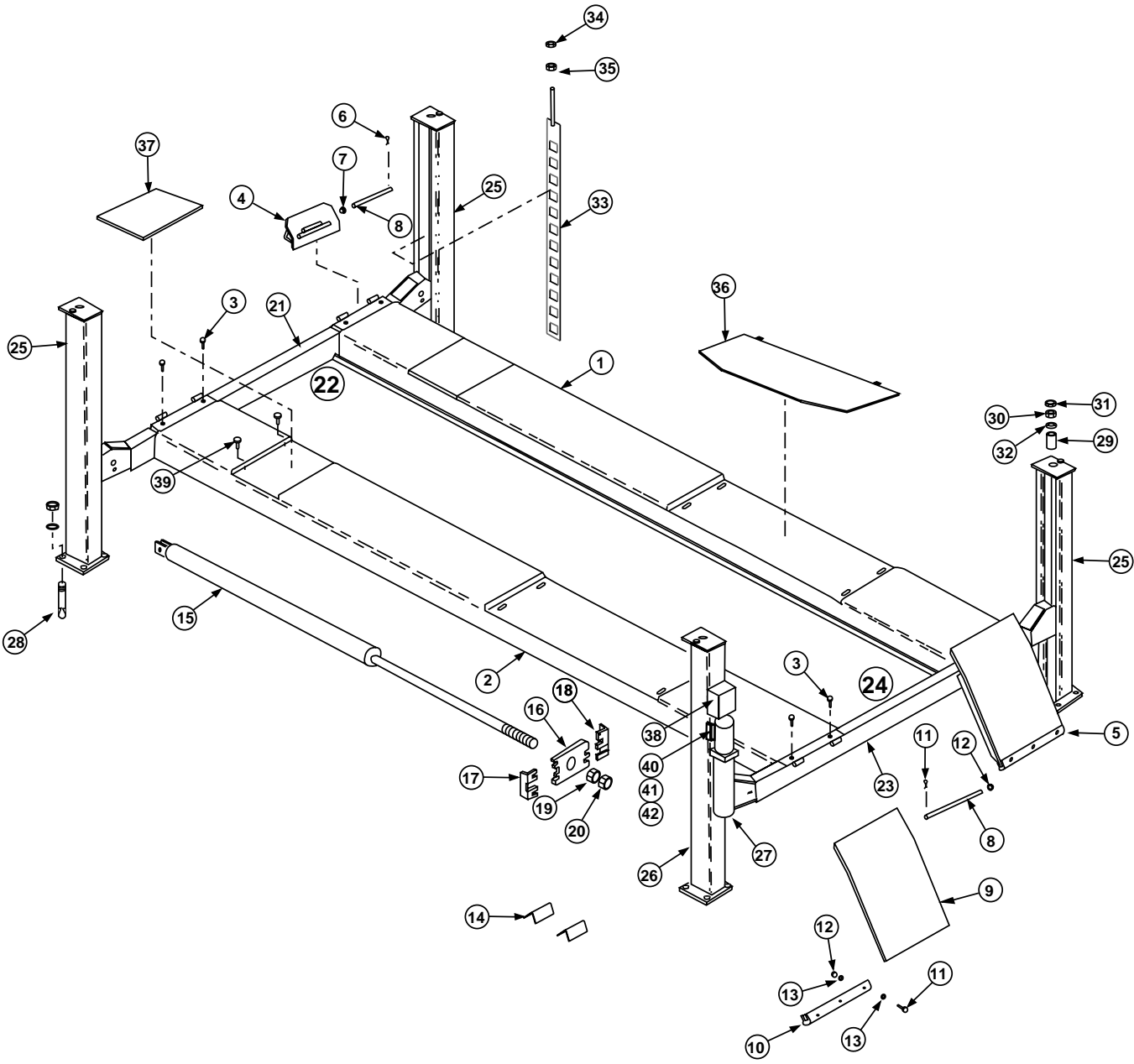

PARTS			
ITEM NO.	DESCRIPTION	PART NO.	
		AR43	AR43-11
1	R.H. (Adjust.) Runway Assembly	FC5911	FC5945-2
2	L.H. (Fixed) Runway Assembly (Includes cylinder, cables and sheaves)	FC5910	FC5945
3	1/2"- 13NC x 1 1/4", Flg. Whiz Lock HHCS (High Strength)	40279	*
4	Wheel Stop	FC134-13	*
5	Ramp Chock Assembly	FC134-12	*
6	5/32" x 1" Lg. Cotter Pin	41202	*
7	5/8" Pushnut Fastener — TRW #PW625019 Or Equal	FC5179-4	*
8	Hinge Pin	FC134-99	*
9	Ramp Chock	FC134-65	*
10	Ramp Chock Slide	FC134-33	*
11	#10-24 PNHDMS x 3/4" Lg.	40030	*
12	#10-24 Hex Nut	40630	*
13	#10 Plain Washer	40785	*
14	Triangular Wheel Chock	FC320	*
15	Hydraulic Cylinder	FC5797	*
16	Cable Pull Bar	FC543-6	*
17	L.H. Cable Retaining Bar	FC543-3	*
18	R.H. Cable Retaining Bar	FC543-2	*
19	1 3/8"-6NC Hex Nut	40771	*
20	1 3/8"-6NC Hex Jam Nut	40773	*
21	Front Yoke	FC5938-1	*
22	Front Yoke Ass'y. (Including Latches)	FC5940	*
23	Rear Yoke	FC5939-1	*
24	Rear Yoke Ass'y. (Including Latches)	FC5939	*
25	Column	FC5704	*
26	Power Unit Column	FC5704-10	*
27	Power Unit	P1081	*
28	5/8" Anchor Bolt	FC5228	*
29	Spacer	FC5287	*
30	7/8"-9NC Hex Nut	40765	*
31	7/8"-9NC Hex Jam Nut	40766	*
32	7/8" Flat Washer	41073	*
33	Latch Bar	FC5704-3	*
34	3/4"-10NC Hex Jam Nut	40759	*
35	3/4"-10NC Hex Nut	40760	*
36	Rear Slip Plate Kit	FC5249	*
37	Filler Plate	FC5102	*
38	Control Box	FA7166	*
39	1/4"-20NC x 5/8 Flg. Whiz-Lock HHCSZpl	42000	*
40	Air Valve Bracket	S120197	*
41	Air Valve – Electric	FA7166-2	*
42	Toe Guard Switch	S130050	*

\* Part number in left column applies.

# MODELS:

## SM41-1, SM41R, SM43-1, SM43-11

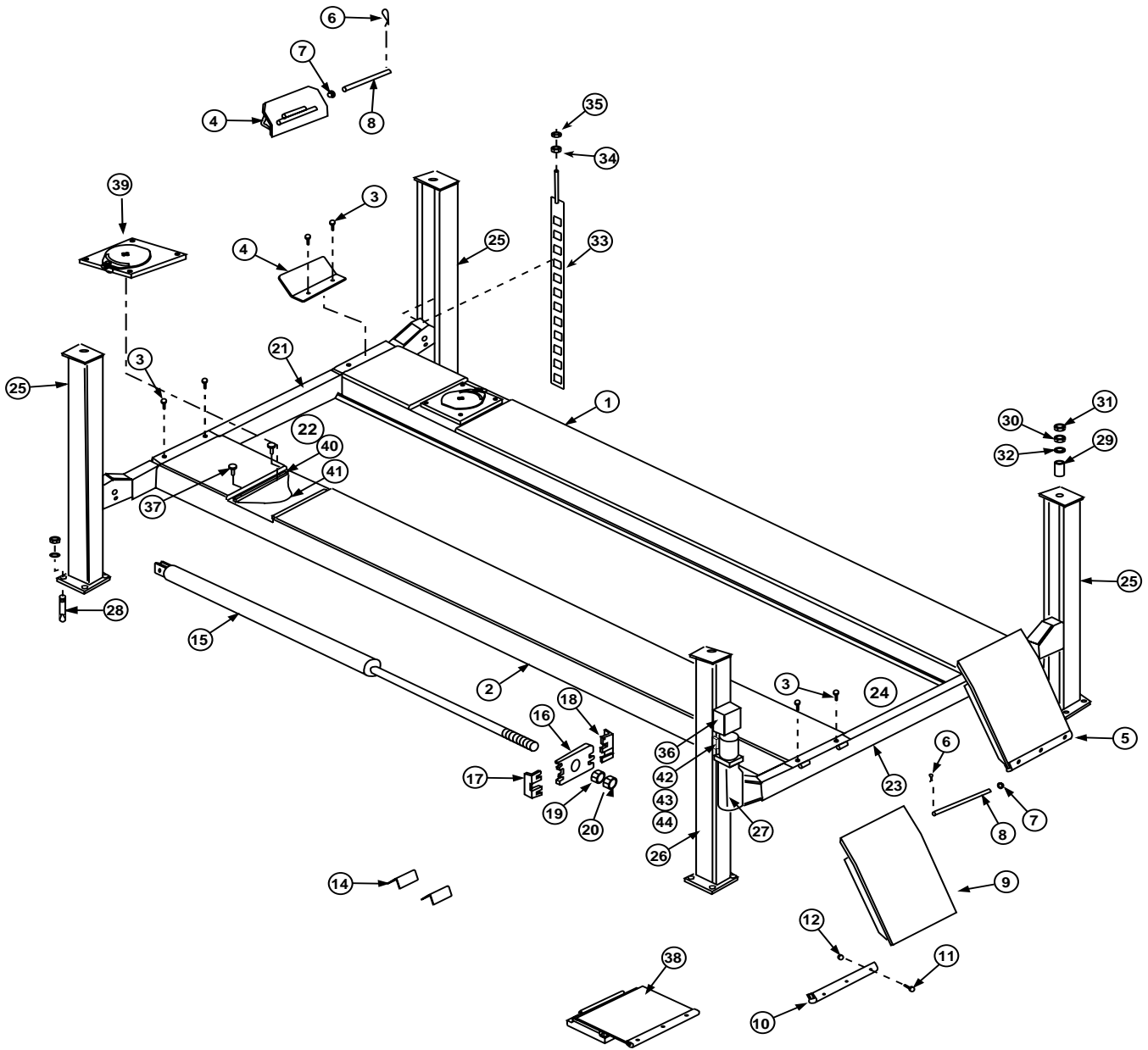

PARTS					
ITEM NO.	DESCRIPTION	PART NO.			
		SM41-1	SM41R	SM43-1	SM43-11
1	Right (Adjust.) Runway Assembly	FC5886-2	FC5893-2	FC5909	FC5944-2
2	Left (Fixed) Runway Assembly (Includes cylinder, cables and sheaves)	FC5886	FC5893	FC5908	FC5944
3	1/2"- 13NC x 1 1/4", Flg. Whiz Lock HHCS (High Strength)	40279	*	*	*
4	Wheel Stop	FC342	*	*	*
5	Ramp Chock Assembly	FC134-12	*	*	*
6	5/32" x 1" Lg. Cotter Pin	41202	*	*	*
7	5/8" Pushnut Fastener — TRW #PW625019 Or Equal	FC5179-4	*	*	*
8	Hinge Pin	FC134-99	*	*	*
9	Ramp Chock	FC134-65	*	*	*
10	Ramp Chock Slide	FC134-33	*	*	*
11	#10-24 PNHDMS x 3/4" Lg.	40030	*	*	*
12	#10-24 Hex Nut	40630	*	*	*
13	#10 Plain Washer	40785	*	*	*
14	Triangular Wheel Chock	FC320	*	*	*
15	Hydraulic Cylinder	FC5797	*	*	*
16	Cable Pull Bar	FC543-6	*	*	*
17	L.H. Cable Retaining Bar	FC543-3	*	*	*
18	R.H. Cable Retaining Bar	FC543-2	*	*	*
19	1 3/8"-6NC Hex Nut	40771	*	*	*
20	1 3/8"-6NC Hex Jam Nut	40773	*	*	*
21	Front Yoke	FC5938-1	*	*	*
22	Front Yoke Ass'y (Including Latches)	FC5940	*	*	*
23	Rear Yoke	FC5939-1	*	*	*
24	Rear Yoke Ass'y (Including Latches)	FC5939	*	*	*
25	Column	FC5704	*	*	*
26	Power Unit Column	FC5704-10	*	*	*
27	Power Unit	P1081	*	*	*
28	5/8" Anchor Bolt	FC5228	*	*	*
29	Spacer	FC5287	*	*	*
30	7/8"-9NC Hex Nut	40765	*	*	*
31	7/8"-9NC Hex Jam Nut	40766	*	*	*
32	7/8" Flat Washer	41073	*	*	*
33	Latch Bar	FC5704-3	*	*	*
34	3/4"-10NC Hex Jam Nut	40759	*	*	*
35	3/4"-10NC Hex Nut	40760	*	*	*
36	Control Box	FA7166	*	*	*
37	1/4"-20NC X 5/8" FLG. WHIZ-LOCK HHCSZpl	42000	*	*	*
38	Flush Mount Ramp	FC327	*	*	*
39	Radius Gauge	FA5157	*	*	*
40	Radius Gauge Retainer	FA5153-1	*	*	*
41	Retaining Cable	*	S130043	*	*
42	Air Valve Bracket	S120197	*	*	*
43	Air Valve	FA7166-2	*	*	*
44	Toe Guard	S13050	*	*	*

\* Part number in left column applies.

# MODELS: SM44R-4 and SM44-4

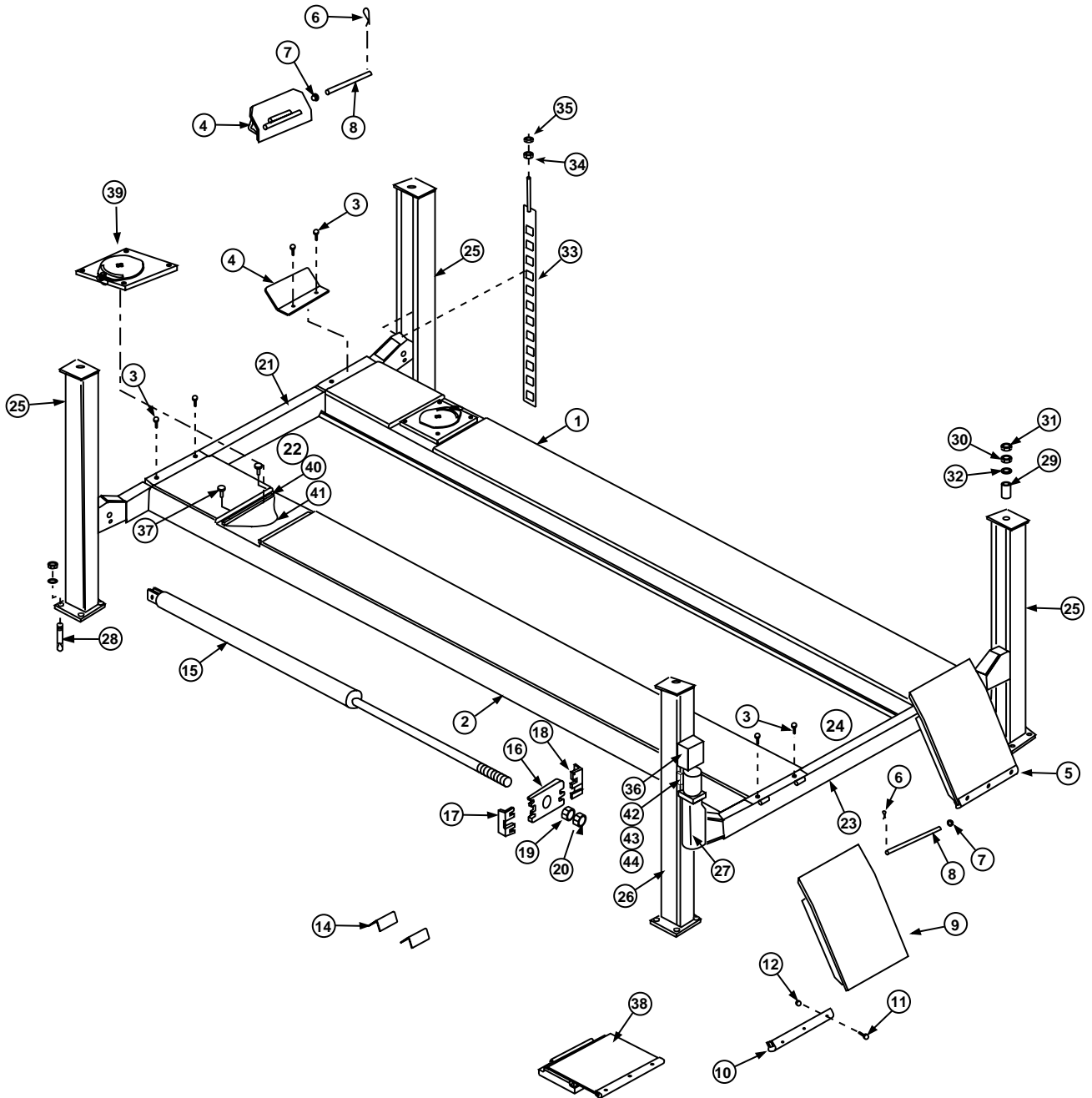

REPLACEMENT PARTS					
ITEM NO.	DESCRIPTION	PART NO.			
		SM44R-4		SM44-4	
1	R.H. (Adjust.) Runway Assembly	FC5913		FC5915	
2	L.H. (Fixed) Runway Assembly (Includes cylinder, cables and sheaves)	FC5912		FC5914	
3	1/2"- 13NC x 1 1/4", Flg. Whiz Lock HHCS (High Strength)	40279		40279	
4	Wheel Stop	FC5804-19		FC5804-19	
5	Ramp Chock Assembly	Left	FC347	Left	FC347
		Right	FC348	Right	FC348
6	5/32" x 1" Lg. Cotter Pin	41202		41202	
7	5/8" Pushnut Fastener — TRW #PW625019 Or Equal	FC5179-4		FC5179-4	
8	Hinge Pin	FC134-99		FC134-99	
9	Ramp Chock	Left	FC345	Left	FC345
		Right	FC346	Right	FC346
10	Ramp Chock Slide	FC134-33		FC134-33	
11	#10-24 PNHMS x 3/4" Lg.	40030		40030	
12	#10-24 Hex Nut	40630		40630	
13	#10 Plain Washer	40785		40785	
14	Triangular Wheel Chock	FC320		FC320	
15	Hydraulic Cylinder	FC5797		FC5797	
16	Cable Pull Bar	FC543-6		FC543-6	
17	L.H. Cable Retaining Bar	FC543-3		FC543-3	
18	R.H. Cable Retaining Bar	FC543-2		FC543-2	
19	1 3/8"-6NC Hex Nut	40771		40771	
20	1 3/8"-6NC Hex Jam Nut	40773		40773	
21	Front Yoke	FC5938-1		FC5938-1	
22	Front Yoke Ass'y (Including Latches)	FC5940		FC5940	
23	Rear Yoke	FC5939-1		FC5939-1	
24	Rear Yoke Ass'y (Including Latches)	FC5939		FC5939	
25	Column	FC5704		FC5704	
26	Power Unit Column	FC5704-10		FC5704-10	
27	Power Unit	P1081		P1081	
28	5/8" Anchor Bolt	FC5228		FC5228	
29	Spacer	FC5287		FC5287	
30	7/8"-9NC Hex Nut	40765		40765	
31	7/8"-9NC Hex Jam Nut	40766		40766	
32	7/8" Flat Washer	41073		41073	
33	Latch Bar	FC5704-3		FC5704-3	
34	3/4"-10NC Hex Jam Nut	40759		40759	
35	3/4"-10NC Hex Nut	40760		40760	
36	Control Box	FA7166		FA7166	
37	1/4"-20NC x 5/8 Flg. Whiz-Lock HHCSZpl	42000		42000	
38	Optional Flush Mount Ramp	Right	FC328	FC328	
		Left	FC329	FC329	
39	Turning Radius Gauge Ass'y.	FA5157		FA5157	
40	Turntable Guide Bar	S120196		S120196	
41	Retaining Cable	S130044		S130044	
42	Air Valve Bracket	S120197		*	
43	Air Valve	FA7166-2		*	
44	Toe Guard Switch	S130050		*	

\* Part number in left column applies.

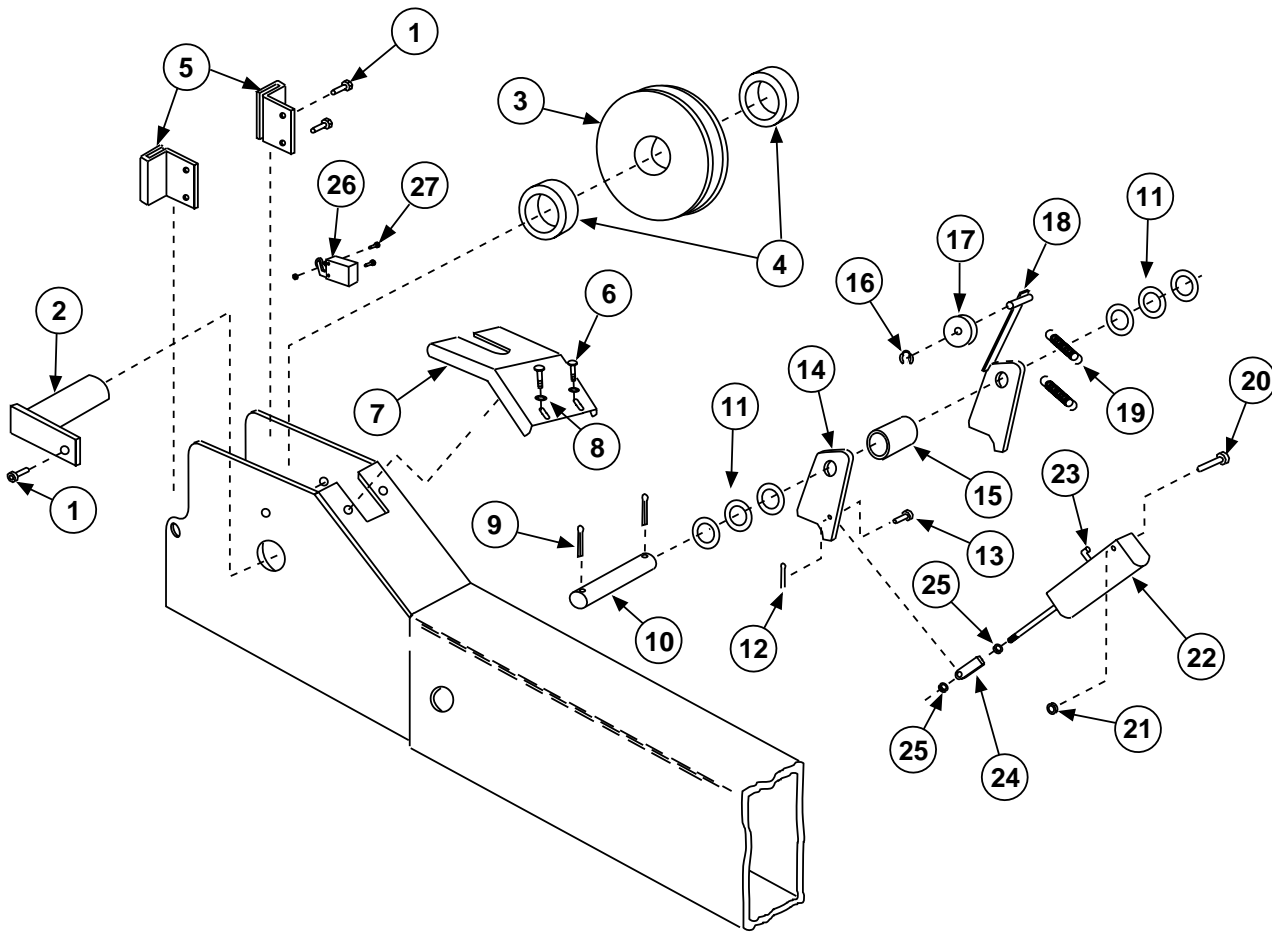

**YOKE END DETAIL**

ITEM NO.	DESCRIPTION	PART NO.	ITEM NO.	DESCRIPTION	PART NO.
1	5/16"-18NC x 1/2" Lg. Button Head Screw	40225	16	3/8" Snap Ring TRUARC #5304-37	41410
2	Sheave Pin	FC5224-21	17	Slack Cable Roller	FC553-21
3	Sheave	FC5804-2	18	Slack Cable Latch	FC5887-6
4	Plastic Spacer	FC5927-10	19	Extension Spring	FC522-25
5	Slider	FC5706-16	20	1/4"-20 HHCS X 1 1/2" Lg.	40081
6	1/4" 20NC HHTS x 1/2" Lg.	40067	21	1/4"-20 Hex Nut w/locking nylon insert	40642
7	Yoke End Guard	FC5802-18	22	Air Cylinder	FC5706-17
8	1/4" Plain Washer	40780	23	Elbow	FC5224-39
9	Cotter Pin, 1/8" X 1 1/4"	41201	24	Clevis	FC5706-7
10	Latch Shaft	FC5224-17	25	1/4" -28NF Hex Nut	40622
11	Washer	FC5301-98	26	Limit Switch	N411-1
12	1/4" Hairpin Cotter Pin (.05" dia. wire)	41901	27	Bolt and Nut	2 req'd.
13	Clevis Pin	FA2230-12	28	Elbow	FC5887-8
14	Latch	FC5706-10			
15	Spacer	FC5706-9			



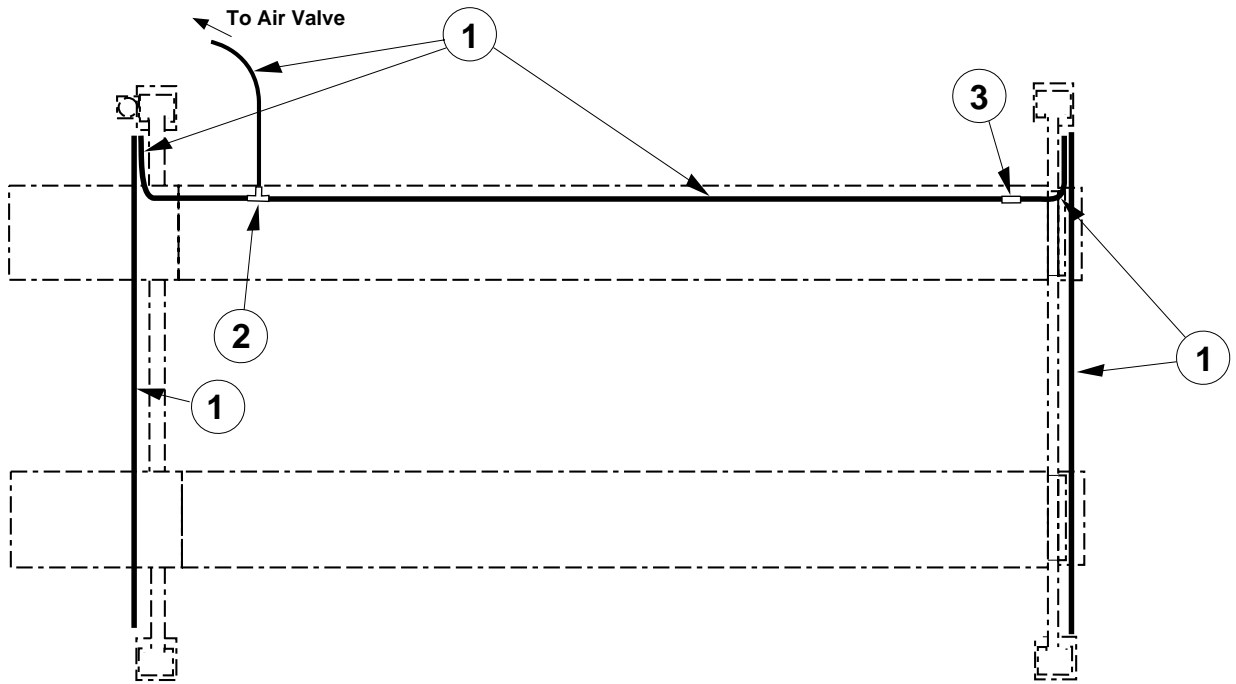

AIR LATCH AIRLINE DETAIL		
ITEM NO.	DESCRIPTION	PART NO.
1	1/4" Airline Tubing (50' roll)	FA2230-2
2	Union Tee	FC5225-46
3	Union	FC5225-98

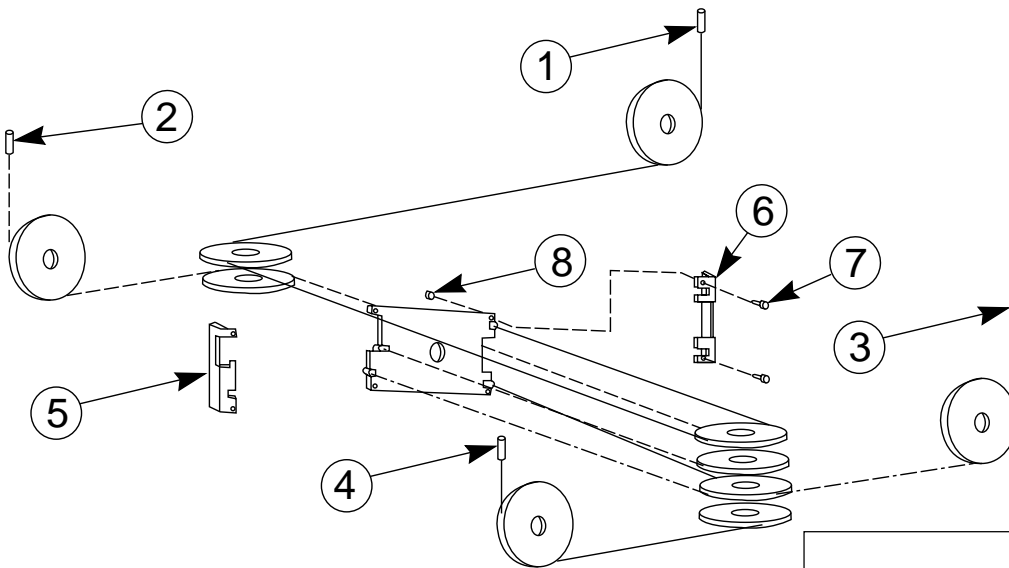

CABLES				
ITEM NO.	DESCRIPTION	PART NO.		
		AR41-1 SM41-1 SM41R	AR43-1 SM43-1 SM44-4 SM44R-4	AR43-11 SM43-11
1	Right Front Cable	FC5886-8	FC5912-3	FC5944-3
2	Left Front Cable	FC5886-7	FC546	FC5618
3	Right Rear Cable	FC5886-6	*	*
4	Left Rear Cable	FC544	*	*
5	Left Cable Retaining Bar	FC543-3	*	*
6	Right Cable Retaining Bar	FC543-2	*	*
7	1/4"-20NC HHCS X 1 1/2"	40081	*	*
8	1/4"-20NC Hex Nut w/ locking nylon	40642	*	*

\* Part number in left column applies.

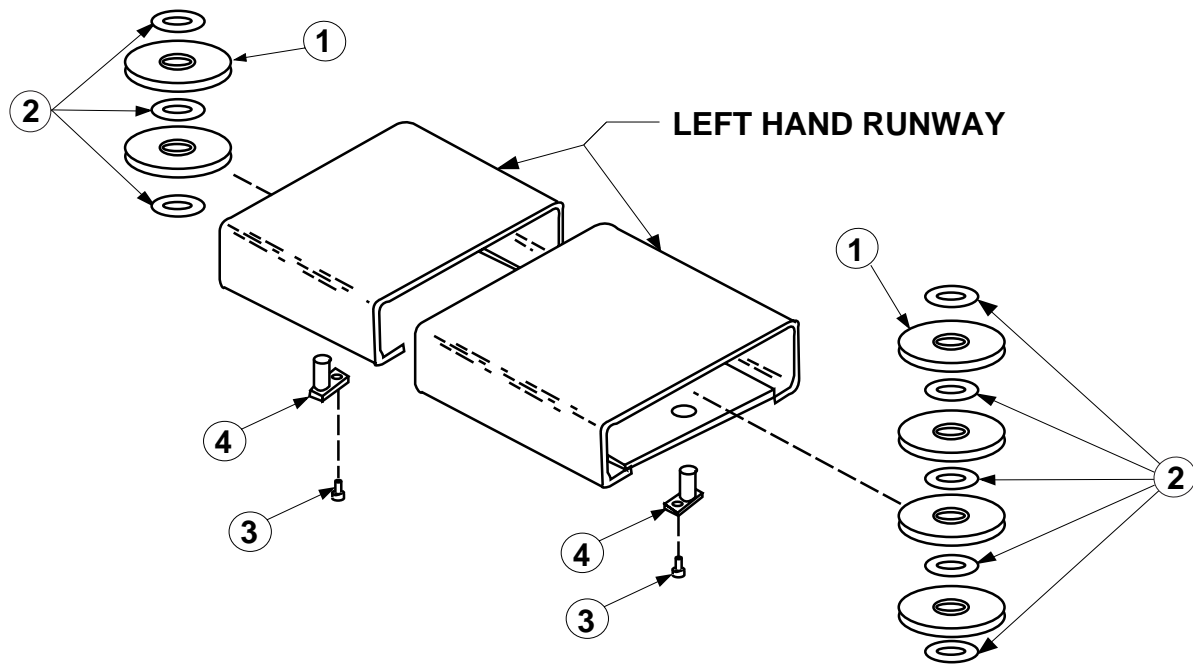

SHEAVE DETAIL		
ITEM NO.	DESCRIPTION	PART NO.
1	Sheave	FC5804-2
2	Plastic Bearing	FC5843-3
3	5/16"-18NC HSBHCS x 1/2" Lg.	40225
4	Sheave Pin	FC555-1

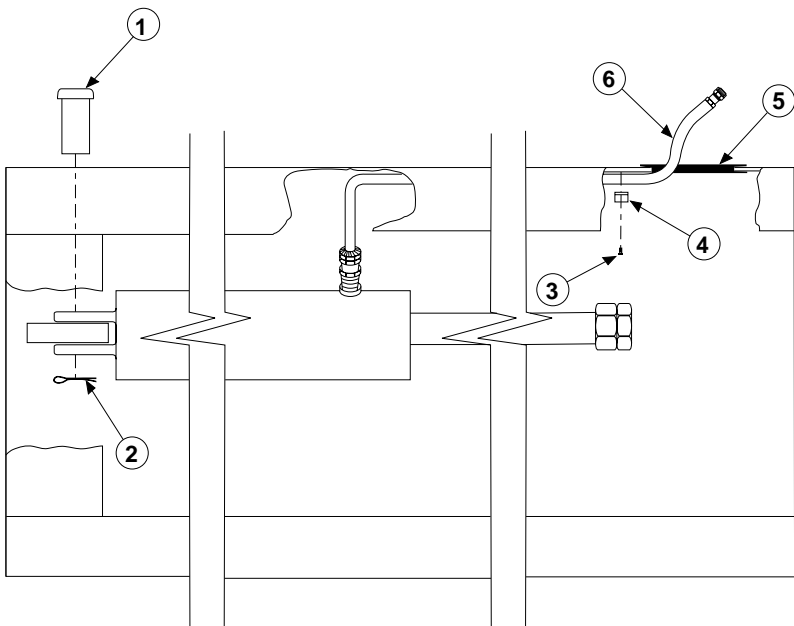

HYDRAULIC HOSE DETAIL		
ITEM NO.	DESCRIPTION	PART NO.
1	Clevis Pin	FC5346-1
2	3/16" x 1 1/4" Lg. Cotter Pin	41247
3	#10 - 24NC Slotted HHTS x 5/8" Lg.	40029
4	Clamp	FA2239-1
5	Strip Grommet	FC5317-12
6	Hose	FC5798

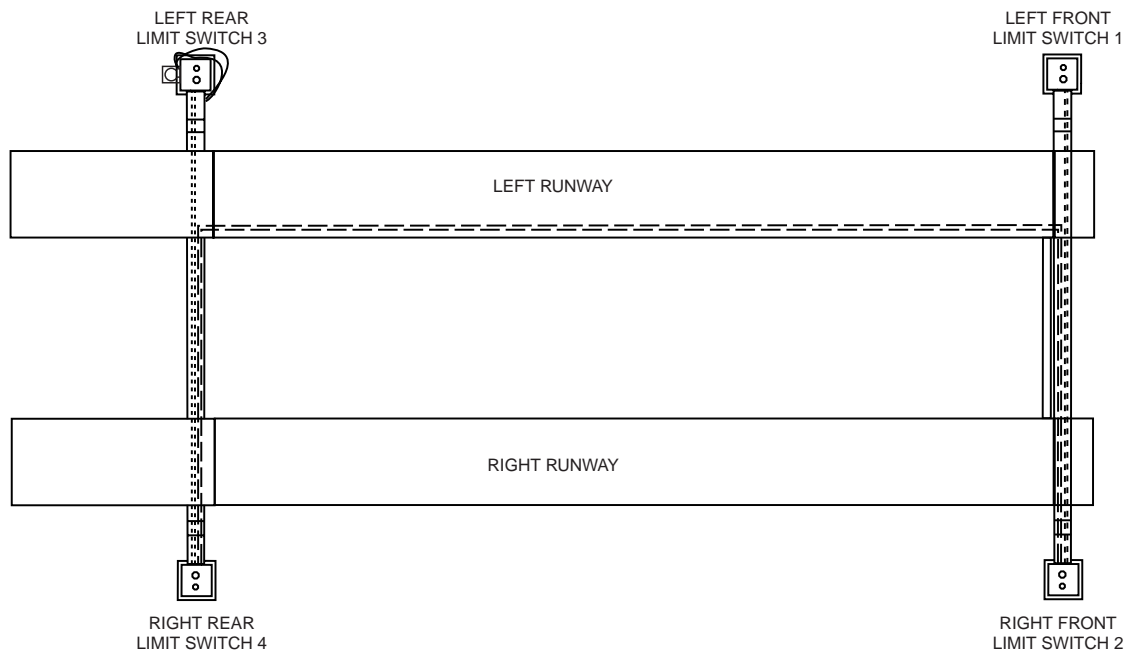

LIMIT SWITCH WIRING		
ITEM NO.	DESCRIPTION	PART NO.
1	Left Front Switch	FC5916-12
2	Right Front Switch	FC5916-13
3	Left Rear Switch	FC5888-12
4	Right Rear Switch	FC5888-13

**IMPORTANT:** When ordering parts or requesting service, always give exact model and power unit serial number. Model number is shown on nameplate attached to power unit column. Power unit serial number is located on side of reservoir.

**NOTES:**

**OWNER'S RECORD**

Complete information at right and keep in a safe place.

Date Installed \_\_\_\_\_

Installed In Bay # \_\_\_\_\_

Std. Pwr. Unit Serial # \_\_\_\_\_ Model # \_\_\_\_\_

Lift Serial # \_\_\_\_\_

Model # \_\_\_\_\_

**NOTE:** For Replacement Parts - See Your Nearest Rotary Parts Distributor